

SU40TL Debris loader on suspension frame

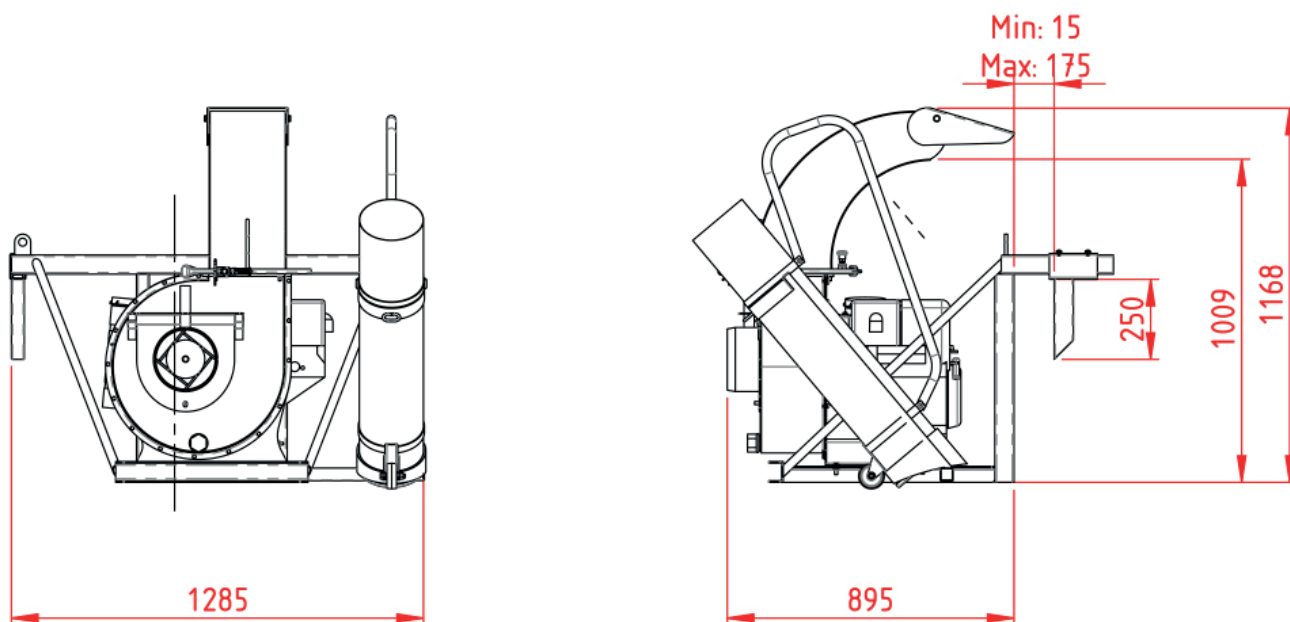

Measures are in mm

Technical specifications

| | |
|-----------------------|------------------------------|
| Fan diameter: | Ø 400 mm |
| Number of fan blades: | 4 |
| Drive: | fan belt |
| Weight: | 175 kg |
| Measurements (LxWxH): | 0,90 x 1,29 x 1,17 m |
| Engine: | Honda GXV340 (recoil) |
| Air capacity: | 180m ³ /min. |
| Noise level: | 106 dB(A) |
| Wander hose: | Ø 200 mm with 5 meter radius |

Under our policy of continuous improvement, we reserve the right to change specifications and design without prior notice. The illustrations do not necessarily show the standard version of the machine. Not all products are available in all countries.