

Saugwagen S4-C4-M4

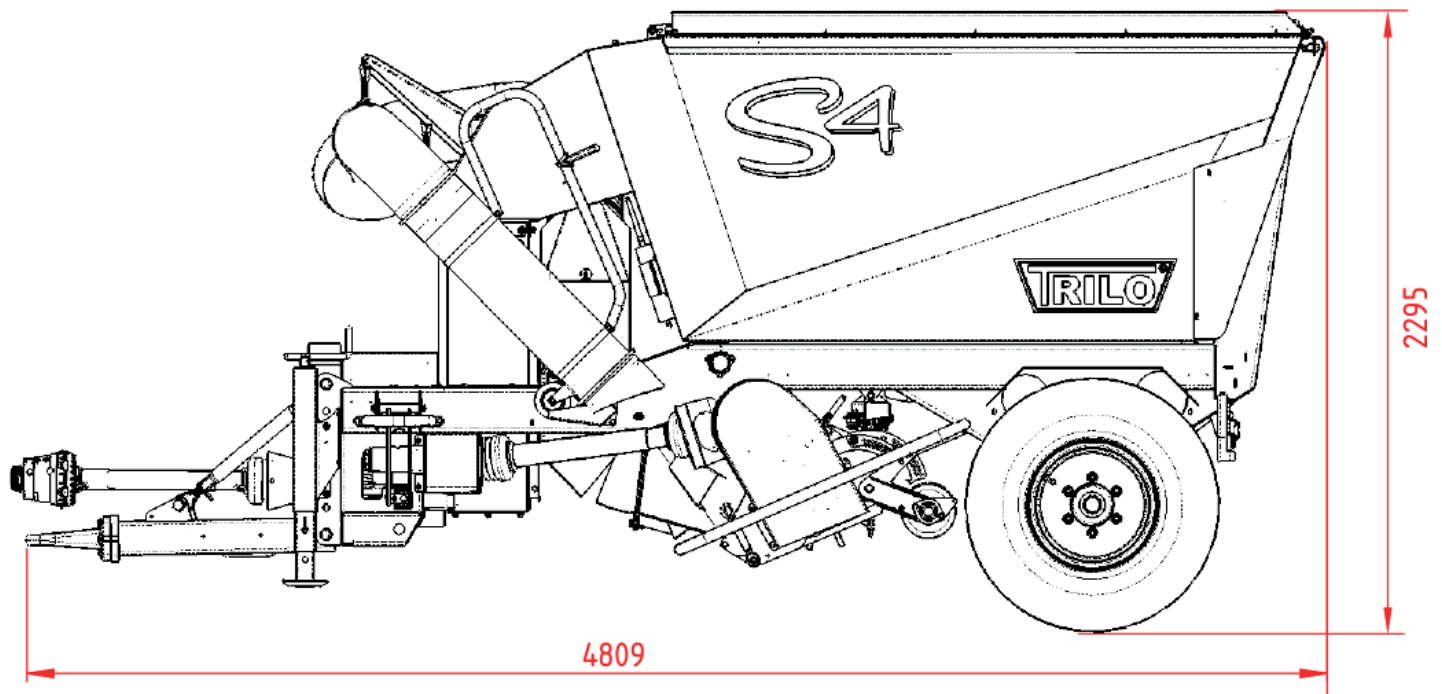

Technische Spezifikationen

Turbine:	Ø 850 mm
Flügel/Turbine:	4
Erforderliche Zapfwellenleistung (Mähen und Sammeln):	70 - 90 ps (51 - 66 kW)
Erforderliche Zapfwellenleistung (fegen & sammeln):	45 - 70 PS (33 - 51 kW)
Erforderliche Zapfwellenleistung (Saugschlauch):	35 - 50 PS (26 - 36 kW)
Zapfwelle:	540 U/Min.
Erforderliche Hydraulikleistung:	180 bar - 40 l/min.
Erforderliche Hydraulikanschlüsse:	1 x doppelt wirkenden Hahn
Abmessungen (LxBxH):	4,75 x 2,05 / 2,35 x 2,23 m
Luftdurchsatz:	315 m ³ /min.
Geräuschemission:	84 dB(A)
Behälterinhalt:	4 m ³
Handschlauch:	Ø 250 mm, Länge 5 + 1 meter (Optional)
Arbeitsbreite (fegen & sammeln):	1,8 / 2,1 / 2,4 m
Arbeitsbreite (Mähen und Sammeln):	1,8 / 2,1
Bereifung:	500/50R17

Im Rahmen unserer kontinuierlichen Verbesserung behalten wir uns das Recht vor, Spezifikationen und Design ohne vorherige Ankündigung zu ändern. Die Illustrationen zeigen nicht unbedingt die Standardversion der Maschine.

Saugwagen S4-C4-M4

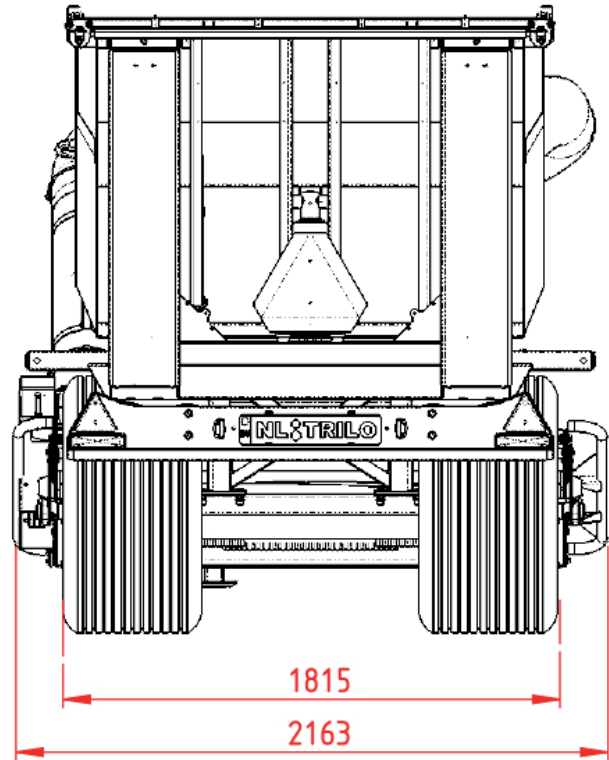
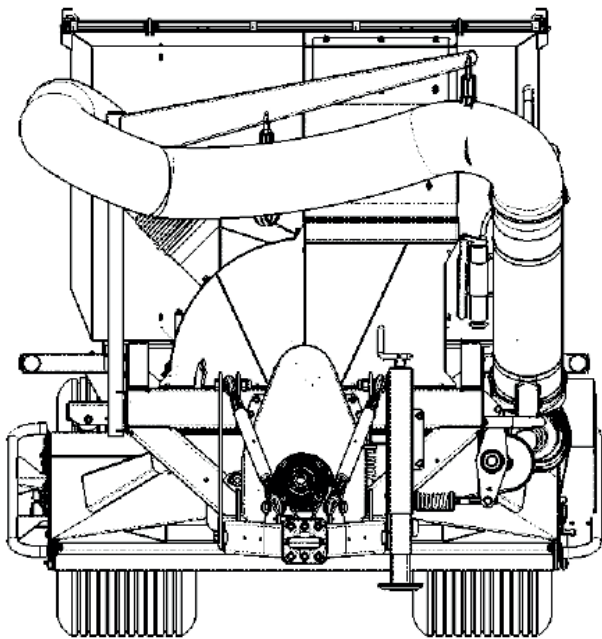

Maße sind in mm

Saugdüse Breite

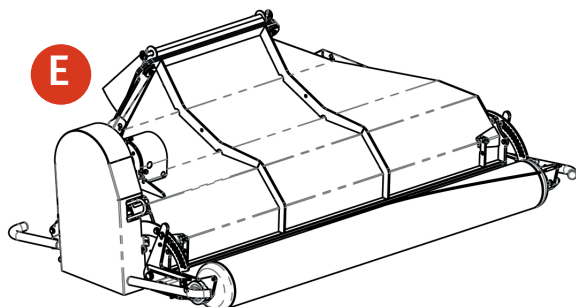
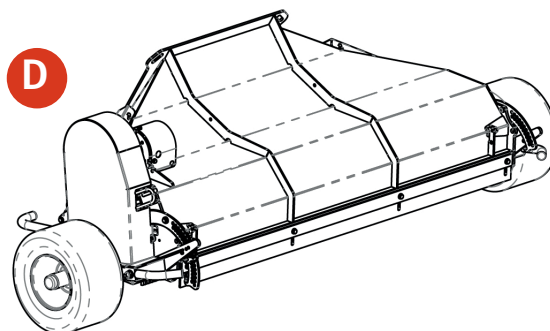
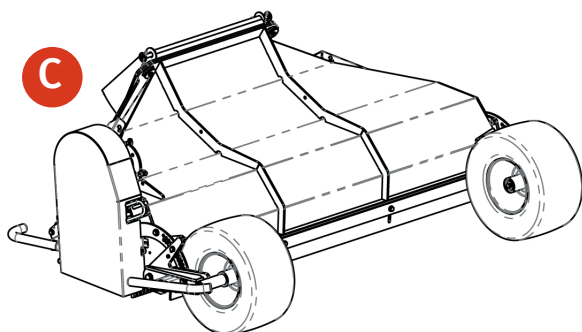
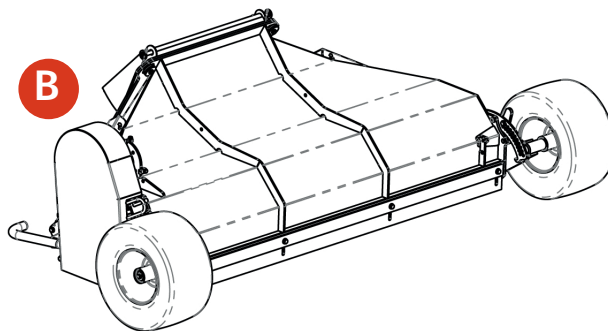
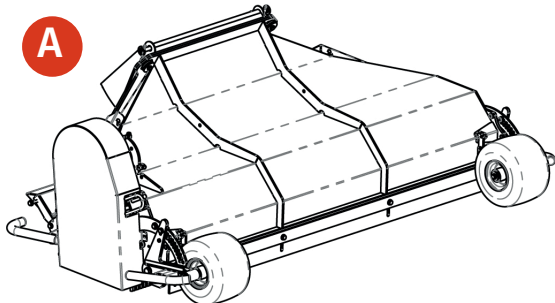

Type	Roller/Tyre	Tyre Type	Height range	Working width - Overall width				Field of application
				1.80 m	2.10 m	2.40 m	3.00 m	
A	11 x 7.00 (Default)	Air or Foam Filled Tyre	-5..13 cm	2.12 m	2.42 m	2.72 m	x	General, Road use, Offroad, Compact
B	18 x 9.50 (Slick)	Air or Foam Filled Tyre	-5..15 cm	2.46 m	2.76 m	3.06 m	x	Turf Production Wide Area Collector
C	16 x 9.50 (Slick)	Air or Foam Filled Tyre	-5..15 cm	x	x	2.72 m	x	Turf Production Wide Area Collector
D	16 x 9.50	Air or Foam Filled Tyre	-5..10 cm	2.70 m	3.00 m	3.30 m	x	Golf course
E	Roller (Default)	Steel	-5..15 cm	2.12 m	2.42 m	2.72 m	x	Mowing