



Large multi-purpose vacuum sweepers (M8 - M20)

Technical specifications

Fan diameter:	Ø 960 mm (37.79")
Number of fan blades:	6
PTO power with suction hose:	65 - 100 pk (49 - 75 kW)
Sweep & Collect PTO Power:	75 - 110 pk (51 - 81 kW)
Mow & collect PTO power:	90 - 130 pk (66 - 130 kW)
PTO:	540/750/1000 RPM
Required hydraulics:	180 bar - 40 l/min.
Required hydraulic connections:	2x double acting minimum
Weight:	depending on configuration
Air capacity:	390 m ³ /min.
Noise level:	85 dB(A)
Loading capacity:	8 - 10 - 12 - 14 - 16 - 20 m ³
Wander hose:	Ø 250 mm (9.8") - 5 + 1 m (16.4 + 3.28 ft)
Suction hose:	Ø 350 mm (13.7") - 4 m (13 ft)
Working width	180 - 210 - 240 - 300cm (5.9 - 6.9 - 7.9 - 10 ft)
Tyres:	505/50R17 or 435

8 m³

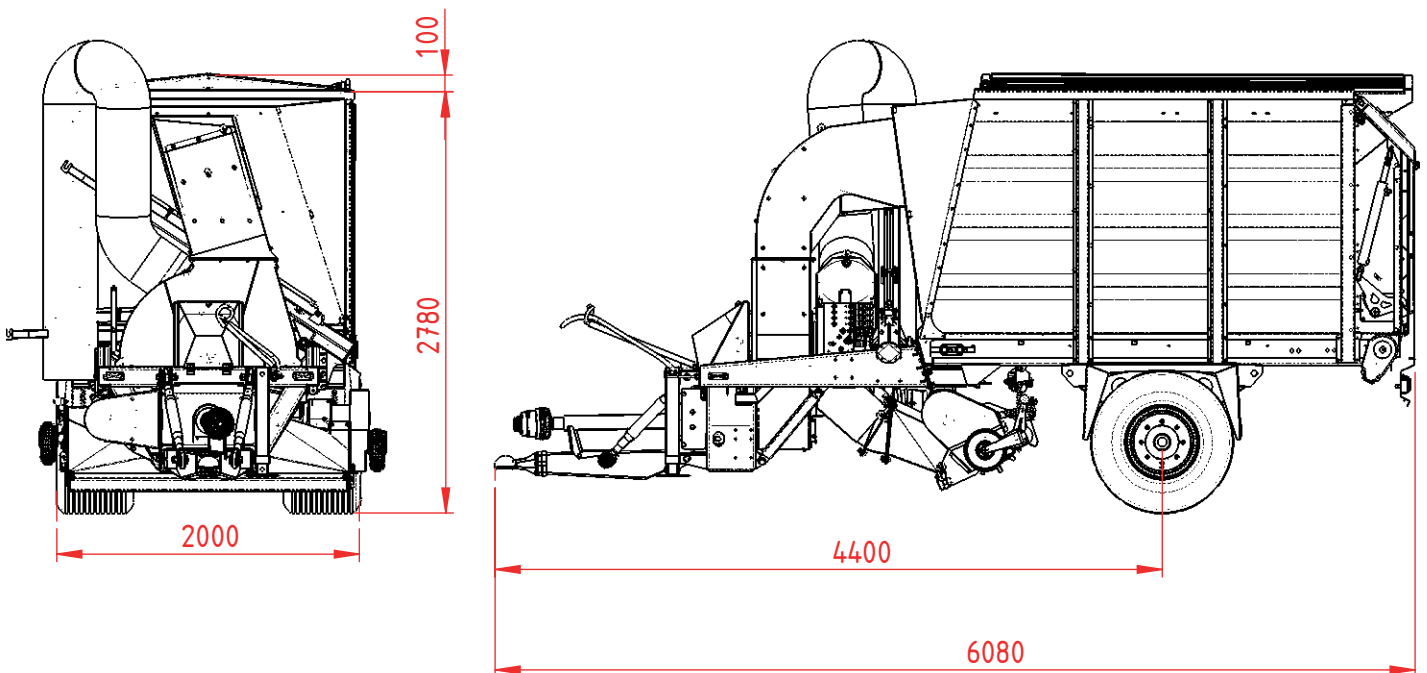

Under our policy of continuous improvement, we reserve the right to change specifications and design without prior notice. The illustrations do not necessarily show the standard version of the machine. Not all products are available in all countries.

10 m³

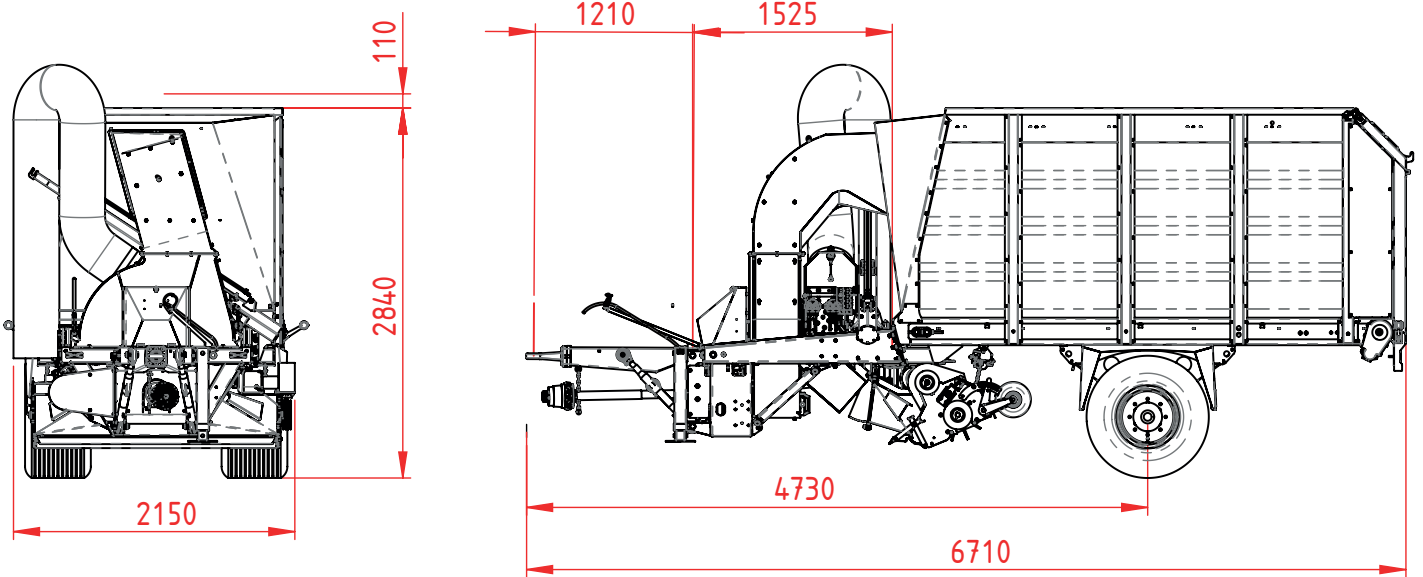

12 m³

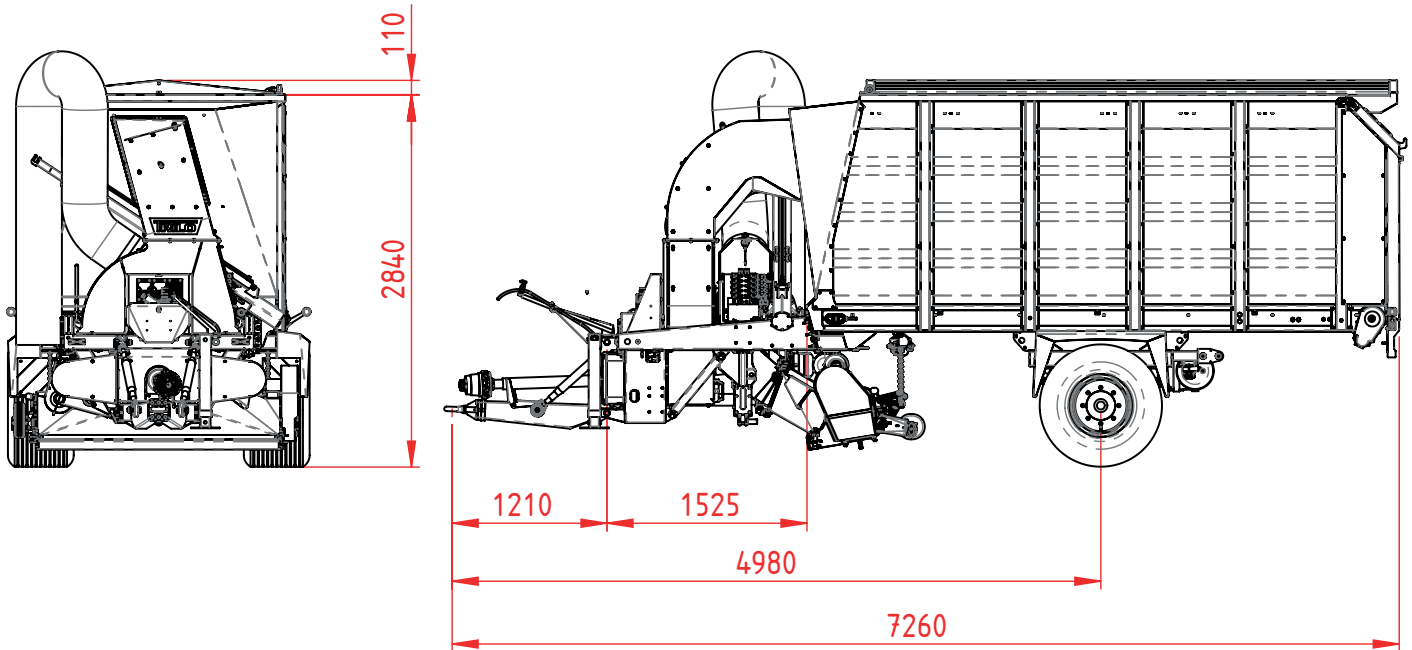

Under our policy of continuous improvement, we reserve the right to change specifications and design without prior notice. The illustrations do not necessarily show the standard version of the machine. Not all products are available in all countries.

14 m³

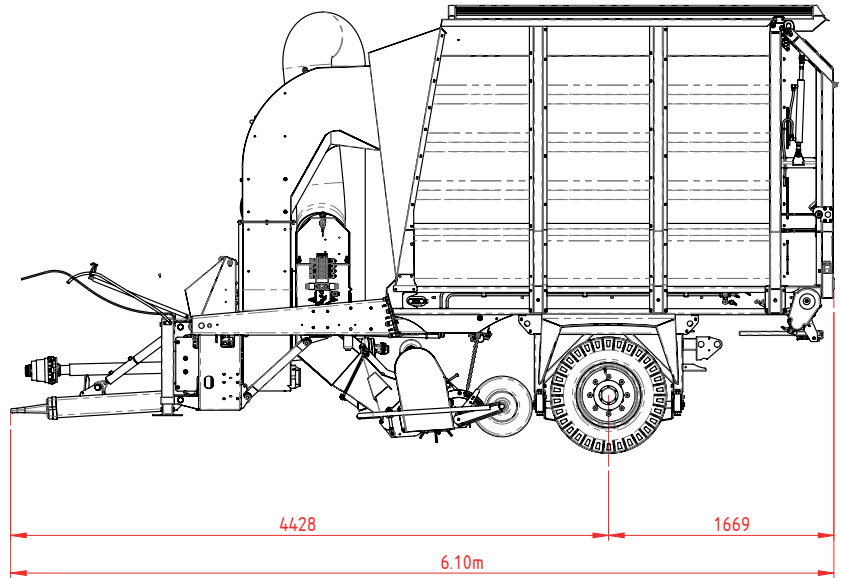
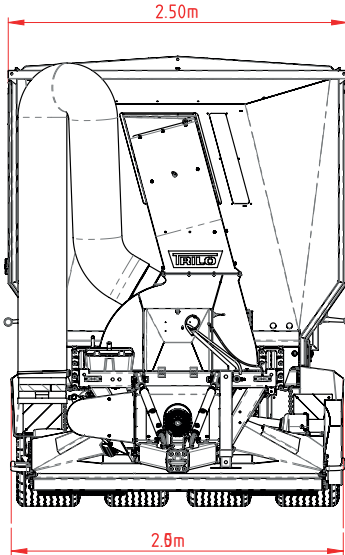

16 m³

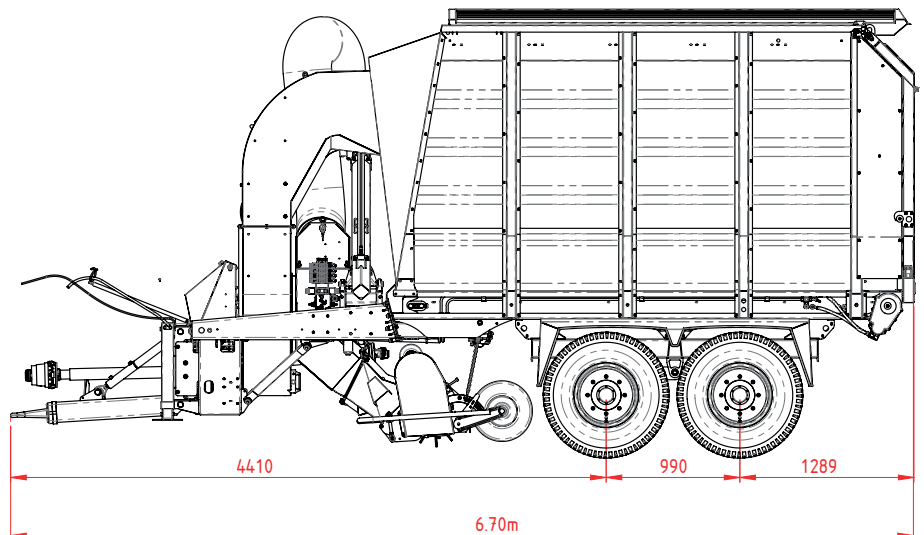
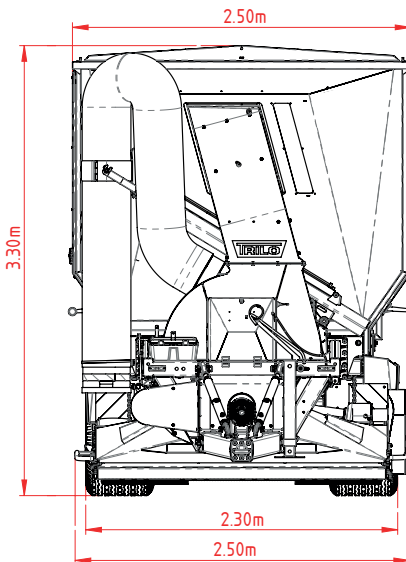

Under our policy of continuous improvement, we reserve the right to change specifications and design without prior notice. The illustrations do not necessarily show the standard version of the machine. Not all products are available in all countries.

20 m³

