

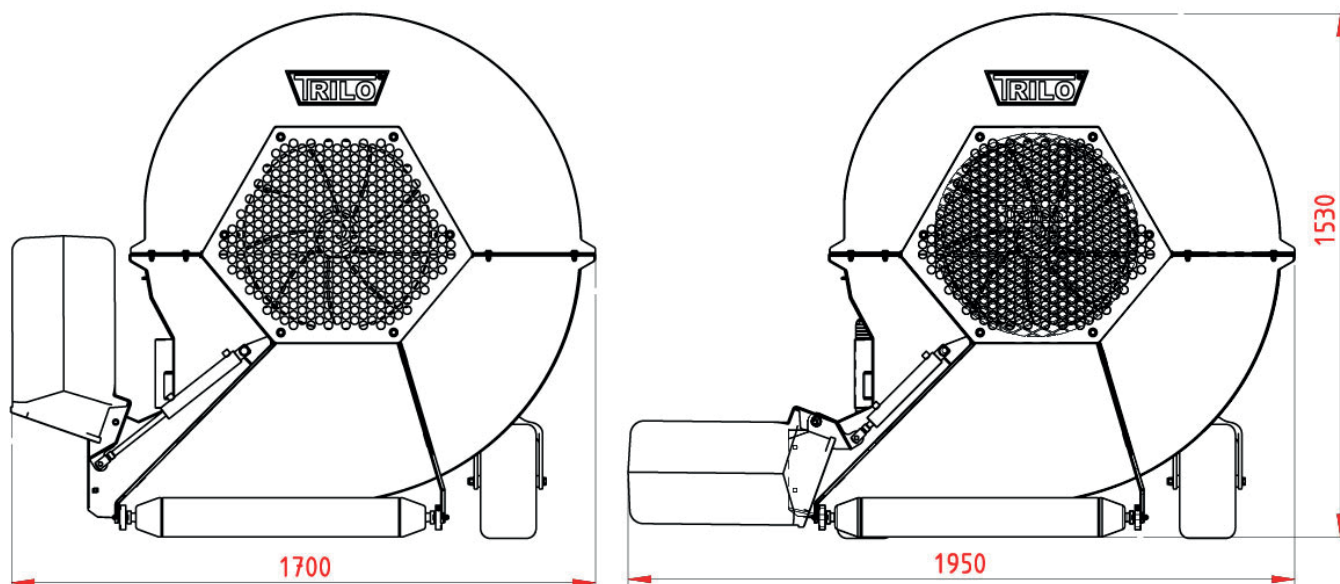

BL960 Blowers



Measures are in mm

Technical specifications

Fan diameter:	Ø 960 mm (37.7")
Number of fan blades:	9
PTO output:	> 50 hp (37 KW)
Castor wheels:	13x6.50-6
PTO:	540 RPM
Drive:	Power take-off
Three point hitch:	Cat I-II
Required hydraulics:	120 bar - 15 l/min.
Required hydraulic connections:	1 x double acting
Weight:	405 kg (893 lb)
Measurements (LxWxH):	1,42 x 1,22 x 1,68 m (4.65 x 4 x 5.5 ft)
Air capacity:	385 m ³ /min.
Noise level:	98 dB(A)

Under our policy of continuous improvement, we reserve the right to change specifications and design without prior notice. The illustrations do not necessarily show the standard version of the machine. Not all products are available in all countries.



BL960 Blowers

